

Multi-Protocol Network Transmitter BACnet® MSTP • Modbus RS485 • BACnet® IP • LonWorks® FT

For CO, NO₂ and Temperature Measurement

Key Features

- Intended for ventilation control in enclosed spaces with operating vehicles including parking garages, vehicle service areas, warehouses and secret underground bases.
- 4 Digital protocol options in one transmitter: BACnet® MSTP, Modbus 485, BACnet® IP and LonWorks® FT utilizing the Adesto 6050 Smart Transceiver.
- The TR2000-DIGI Transmitter can power and provide a multi-protocol digital connection for a separate and optional analog TR3210-NO₂ transmitter, which must often be mounted at a different height than the CO transmitter.
- Digital outputs of the TR2000 DIGI include carbon monoxide, temperature and NO₂ from a remotely mounted AirTest TR3210-NO₂.
- Utilizes a single gang, 4" X 3" X 2.5" electrical box (included), identical to original TR2000 design.
- CO sensing element is certified to UL2075.
- Selectable baud rate adjustment.
- Calibration pots for zero and span calibration.
- Replacement factory-calibrated assembly available.
- Enclosure, appearance and calibration identical to the TR2000 transmitter.

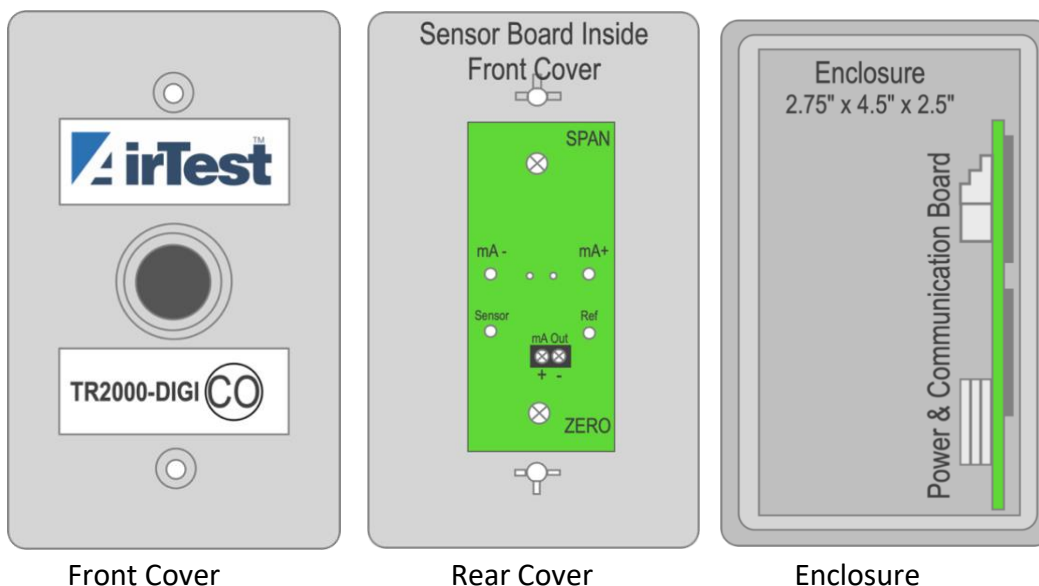

Dimensions and Wiring

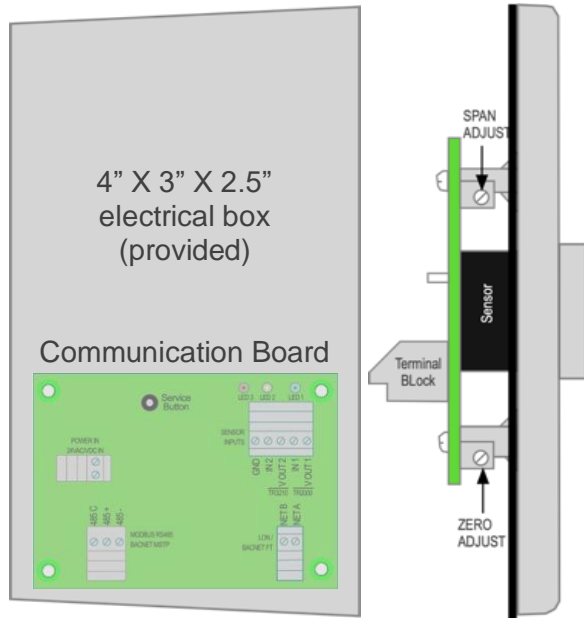

Side View

Power and Communication Board

(Board is removed from enclosure for wiring)

1. 24 VAC Power In
2. BACnet® MSTP, Modbus 485 out
3. Sensor Inputs for CO and NO2 (4-20 mA loop powered) using
4. FT Lon or BACnet® IP out

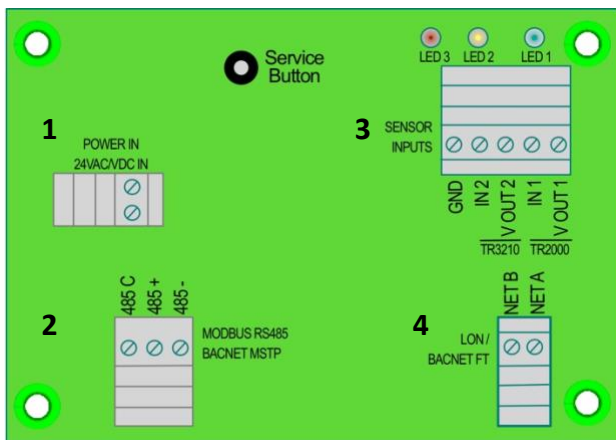

Specifications

General

Measurement: CO, Temperature
 Temp Operating Conditions: -4 to 122° F (-20 to 50°C)
 Temp Storage Conditions: -40 to 158°F (-40 to 70°C)
 RH Operating Conditions: 0 to 90% RH

CO Measurement

Sensing Method: Electrochemical
 Approval: UL2075 Certified Sensor
 Measurement Range: 0-200 ppm
 Sensor Rated Life: 6 years
 Annual Drift: +/- 5% of measured value
 Response Time: T90 = <1 minute (diffusion)
 Warm Up Time: < 2 minutes

Enclosure Temperature:

Method: Thermistor
 Measurement Range: -4 to 122° F (-20 to 50°C)
 Accuracy: ±2.6 °F (±2°C)

Power/Wiring

Voltage: 24VAC ±20%, full wave rectified
 Power Consumption: 50 mA max
 Power Wiring: 18 gauge or larger depending on wire run length

BACnet® MSTP/Modbus RS485 Communication

**! Isolated RS485 connection!
 ! Must use 3-wire connection!**

Wiring: Impedance Options

1. RS485 Rated (120 Ohms characteristic impedance terminated with 120 Ohm resistors at each end) or,
2. CAT5 (100 Ohms characteristic impedance terminated with 100 Ohm resistor at each end). Use one in-cable twisted pairs for RS485 + and RS485 -. Use single wire from a twisted pair for common.

Baud Rate: Adjustable using DIP Switch 2 on Communication Board

TR2000-DIGI LON XIF File

Link: www.AirTest.com/sw/AT2K_060.XIF

TR3210-NO2 Integration

The TR2000-DIGI provides a two-wire connection to the loop powered TR3210-NO2 that allows the sensor to be mounted nearby at a height suitable for local codes requirements. Datasheet:

www.AirTest.com/ds/TR3210.pdf

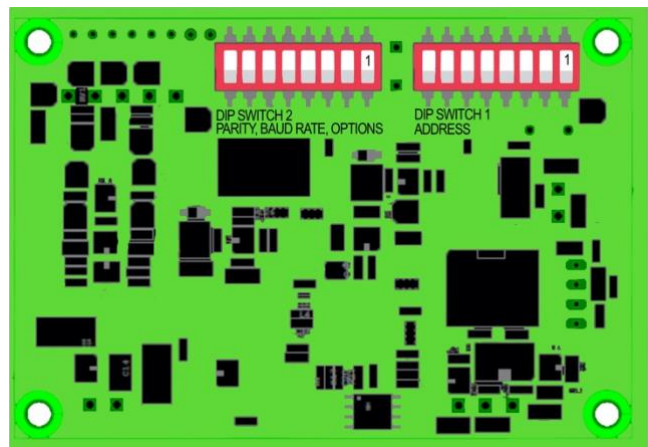

Specifications subject to change without notice



Connecting the TR3210-NO2 Transmitter to the TR2000-DIGI

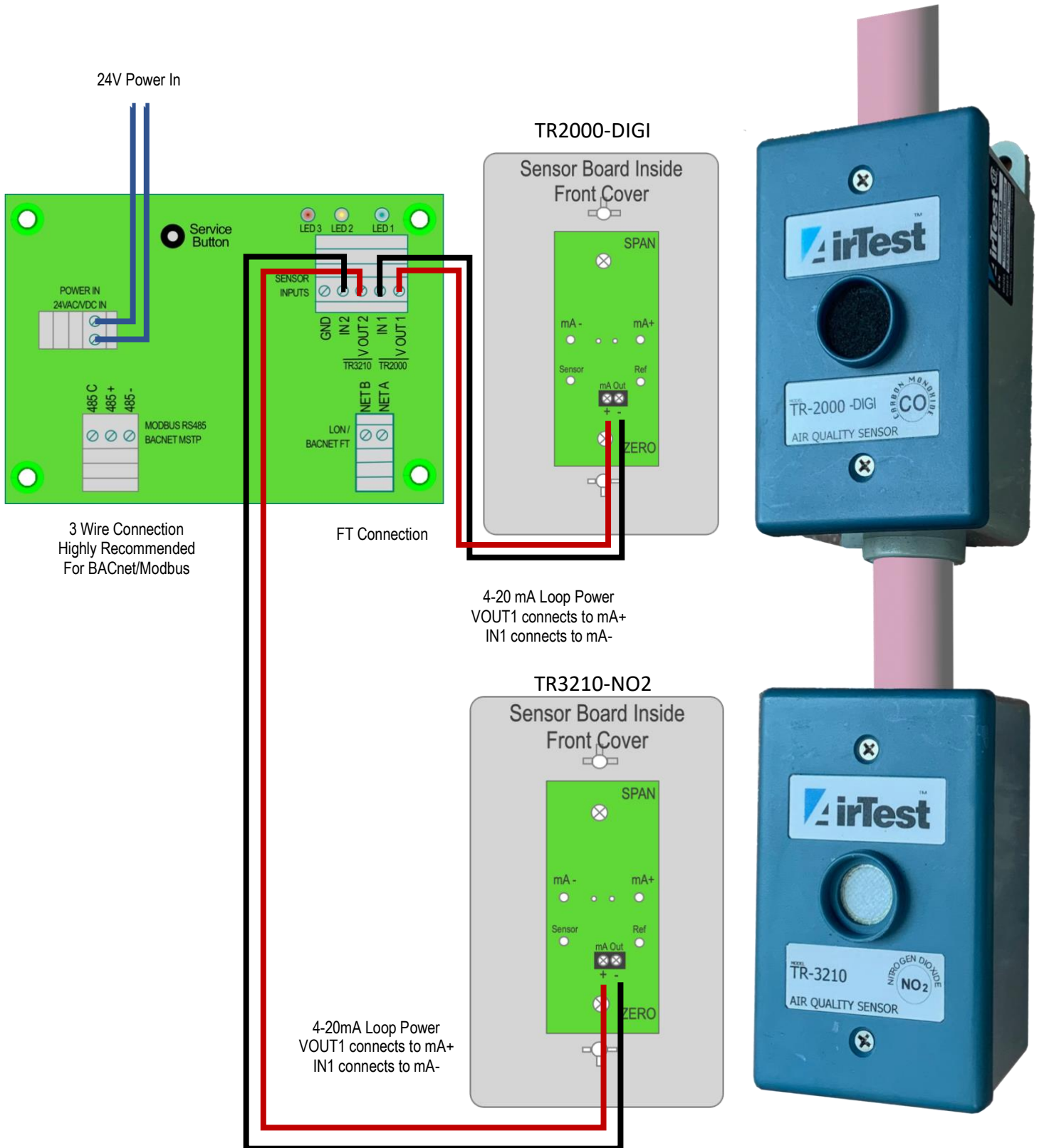

Network Connection Data

Lon Network Variables	Description	Bacnet Objects
LONWORKS NETWORK OUTPUTS / BACNET INPUT OBJECTS		
SNVT_temp_nvoTempP	Temperature: Temperature output reported by on board temp sensor. This sensor is offset by nciTempOffsetP to read closer to ambient when powered from 24 VDC.	Temp In C Temp In F
SNVT_count nvoSw1	S1 Address Dip Switches: 0 is all off This is the MSTP address and 1-127 is valid. A value of 0 tells the firmware not to use the switches. As shipped, the default address is 47 with all switches off. S1 position 8 is ignored.	n/a
SNVT_count nvoSw2	S2 Baud Dip Switches. Position 2 and 1 set the baud as follows Off,Off = 38400, Off,On = 19200, On,Off = 9600, On,On = 4800 As shipped, both positions are off which sets the baud to 38400.	n/a
SNVT_count nvoSwFactory	Factory Jumpers FJ1 to FJ4. Those are all installed by default. They are not be field changeable and not currently used.	n/a
SNVT_lev_percent nvoAI[2]	Percent Reading: Array of two percentage output values that represent the analog input with 0% being 4 ma and 100% being 20 mA. Values below 3.5 mA and above 22.5 mA are considered errors. Values above 3.5 mA but below 4 ma is considered 0%. Errors will be reported as 163.835% which is highest percentage represented. You will see this if nothing is connected. A valid input will cause green led to be on. A value below 3.5 ma will cause green led to be off. A value higher than 22.5 ma is considered a wiring fault and will cause red led to fast flash.	Percent 1 Percent 2
SNVT_ppm_f nvoPpmF[2]	PPM Reading: Array of two floating point output values that represent ppm as scaled using nciPpmMaxF[2]. A floating point NAN will be returned if the inputs are invalid as described above.	PPM 1 PPM 2
CONFIGURATION INPUT NETWORK VARIABLES / BACNET OUTPUT OBJECTS		
SNVT_temp_diff_p nciTempOffsetP	Temp Offset: Default is -7.5 C which is offset temperature between what the on-board temp sensor is reading and an estimate of ambient temperature outside enclosure. This offset affects nvoTempP.	Temp Offset C
SNVT_lev_percent nciAIMinDelta[2]	Analog input delta for throttling network updates of nvoAI[] and nvoPPMF[]. Defaults to 1 percent.	n/a
SNVT_time_sec nciMinSendT	Minimum send time for Analog inputs and temperature for LON bound output network variable transmission throttling. Defaults to 1 second	n/a
SNVT_time_sec nciMaxSendT	Maximum send time for analog inputs and temperature for LON bound output network variable transmission throttling. Defaults to 15 seconds	n/a
SNVT_count neiDaysToCal[2]	Days to Calibrate: Array of two non-volatile input values that indicate number of days to calibrate. Initialized to 1825 for the first which is 5 years and 725 for the second which is 2 years for the second channel. They will decrement once per day. They do not keep track of partial days so if you leave the power off, you will lose days. These are user configurable and saved to non volatile memory. They do not decrement if the input is invalid.	Days To Cal 1 Days to Cal 2
SNVT_ppm_f nciPpmMax[2]	Maximum Gas Values: An array of two input variables that control the maximum PPM for each channel. Initialized for 200 for CO and 10 for NO2. You can set these anywhere you want via Lon and Bacnet. These are user configurable and saved to non volatile memory.	Max PPM 1 Max PPM 2
SNVT_count nciCalWarnDays[2]	Days To Cal Warning: Defaults to 45 days for each of the inputs. If non-zero will start to flash the associated green led for that input to indicate that neiDaysToCal[] is about to become due in less than 45 days in this case. Once neiDaysToCal[] goes to 0, it will fast flash the green led. To disable this warning simply set nciCalWarnDays[] to 0.	

05/12/21